



The new generation
of skid steer loaders.

ELISE 900^{MK3}

first.green

**Fully electric,
noiseless,
zero emission.**



Cost **effective,**
nearly no
maintenance.

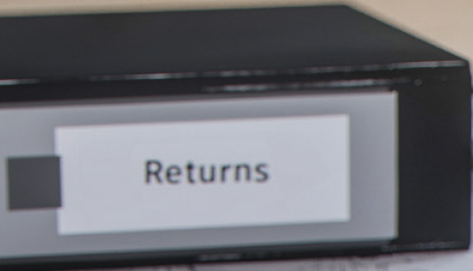

Powered with technology.

Elise 900. The world's first electric skid steer loader represents the highest technology and years of experience of FIRSTGREEN Industries.



Battery endurance

4+ hours

Dependant on use, conditions and configuration

Hinge pin height

3665 mm

384 mm higher reach than the competing average

Battery capacity

240 Ah

With hot-swap battery capability



100% electric, extremely low noise, 0 emission

On stock in 3 days

Low operational costs

Retrofitable modular construction

Microspeed for precise control

Self-leveling gyro platform

Chassis clearance

262 mm

44 mm higher
than competing average

Remote control

50 m

15 m with
smart app

Loading capacity

900 kg

Suitable for most
construction tasks

Technical specs.



GENERAL SPECIFICATIONS

Rated load capacity	900 kg
Tipping load	1 800 kg
Minimum travel speed	0.15 km/h
Maximum speed	12 km/h
Maximum travel speed	12 km/h

MOTOR

Electric engine type	3x Best Motor
Rated power	3x10 kW
Maximum power	3x27 kW
Maximum torque	3x160 Nm

TUNE-UP YOUR MACHINE

Options

- Air conditioning
- Windowless cabin re-build set
- Hard-mounted display
- Rubber or steel track set for increased traction
- Cable set pre-install for electric attachments
- Danfoss remote control
- Lifting points
- Set of wheel with universal tires, heavy terrain tires, smooth surface tires or solid tires
- Set of marking and accessories for road operation

Standard features

- Lead-acid battery with capacity 240 Ah
- External battery charger
- Electric heater
- Battery cover opening for quick battery change
- GPS module
- Apple/Android smartphone with control app
- Rear-view camera
- Left and right rear view mirrors
- Mandatory lightning
- Front work light
- Rear work lights
- Orange beacon light
- Travel alarm
- Emergency exit window
- Front roller sunshade
- Roof tinted glass
- Windscreen wiper with washer
- Safety reinforced cab
- Seat, door and seatbelt sensors
- Speed coupler – SAE J2513
- Self leveling bucket system
- Multiple control option – ISO, H pattern and inverted H pattern

Compare technical specifications for this product online at [first.green](https://www.firstgreen.com)

ELISE 900

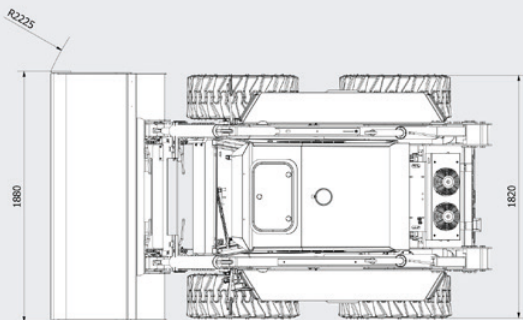
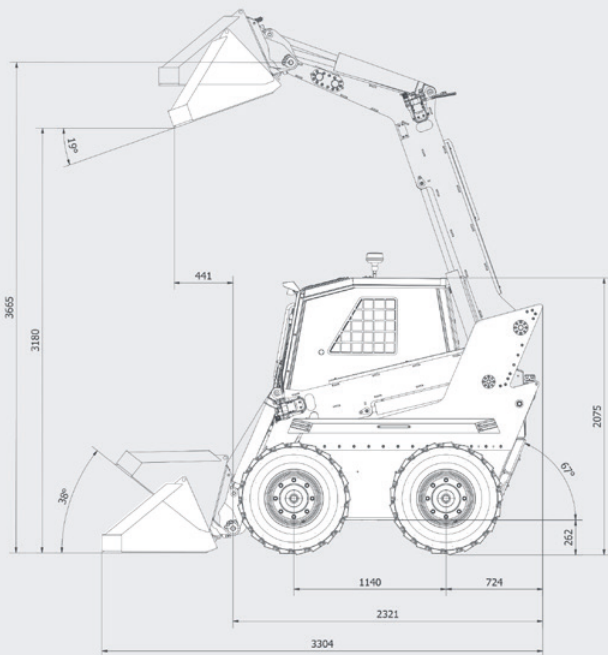

WEIGHTS

Rated operating weight **3 300 kg**

Total weight of the loader **4 200 kg**

HYDRAULICS

Hydraulic oil pressure **180 Bar**

Hydraulic oil flow **65 l/min**

Hydraulic oil reservoir **40 l**

Maintenance



Logistics



Construction



Forestry



Agriculture



With a wide range of attachments.



Standard bucket



Concrete mixer



Pallet forks

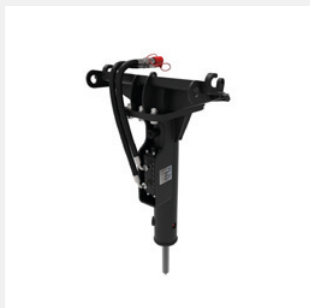

Hammer



Auger

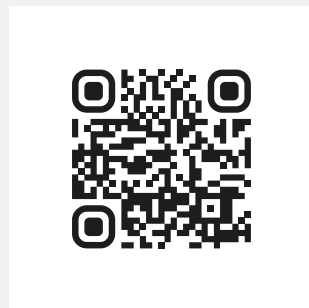

... plus 34 other attachments
on [first.green](https://www.first.green)



For more FIRSTGREEN products, visit
first.green

+420 737 633 733, info@first.green