

The new generation
of compact loaders.

miniZ400

first.green

**MiniZ is more
than a loader,
it is a proven
concept.**

Thanks to constant innovations, we strive to be one step ahead at FIRSTGREEN Industries. We believe in the power of simplicity, which is why we have developed new types of 100% electric compact loaders. Powerful devices with up to 8 hours endurance on a single charge, zero negative impact on the environment, minimal maintenance costs and downtime.



**Extreme power
in compact^{*}
design.**



*** Fits through standard door.**

Compact loader.



MiniZ 400. Compact and precisely manufactured electric loader represents the highest technology and years of experience of FIRSTGREEN Industries.

Battery endurance

6+ hours

Dependant on use, conditions and configuration

Maximum lifting height

2186 mm

Class leading for extreme versatility

Load capacity

400 Kg

Ultimate power in a small package



100% electric, extremely low noise, 0 emission

On stock in 3 days

Lithium battery available

Compact modular construction

Remotely controlled

Ideal for interior work

Powerful tracked drivetrain

Compact dimensions

1150 height
mm / **788** width
mm

Fits through standard
door frames

Remote control

50 m

Maximum reach
for operator safety

Battery capacity

225 Ah

Full charge in
under 5 hours

Technical specifications.



SPECIFICATIONS	
Rated load capacity	400 kg
Tipping load	800 kg
Minimum travel speed	0,1 km/h
Maximum travel speed	5 km/h
Hinge pin height	2 186 mm
Overall width	788 mm

MOTOR	
Electric engine type	1x Benevelli 2x Dana
Rated power	1x 3 kW 2x 2,7 kW

TUNE-UP YOUR MACHINE

Options

- Standard or reinforced rubber tracks
- Cable set pre-install for electric attachments
- Demolition kit with lifting points
- Speed coupler – FGI or TORO DINGO
- Lead-acid battery with capacity 48V/225 Ah
- Lithium battery with capacity 48V/210 Ah and fast charging capability
- Lithium battery with capacity 48V/136 Ah and fast charging capability
- Lithium dual battery with capacity 48V/272 Ah and fast charging capability
- Operator platform

Standard features

- External battery charger
- Danfoss remote control
- GPS module
- Danfoss hydraulic system
- Independent motors – 2 for drive, 1 for hydraulic
- Micro-speed control

Compare technical specifications for this product online at [first.green](https://www.first.green)

miniZ400

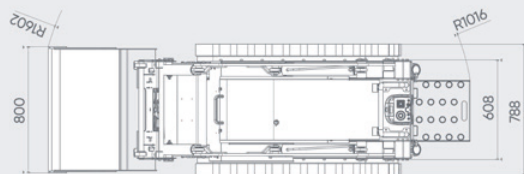
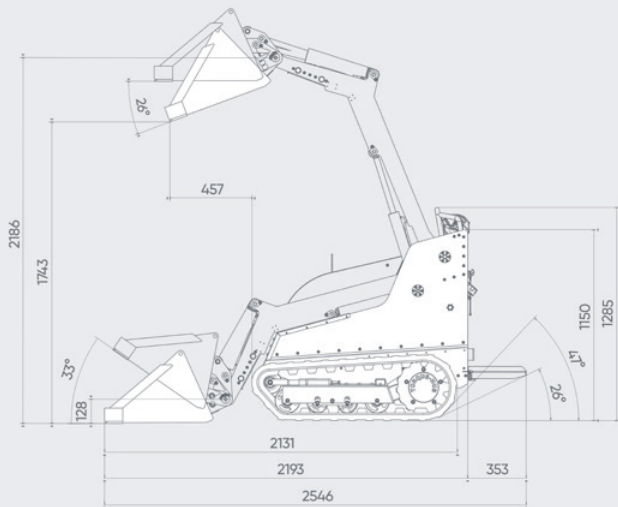

WEIGHTS

Rated operating weight 1 100 kg

Total weight of the loader 1 500 kg

HYDRAULICS

Hydraulic oil pressure 150 bar

Hydraulic oil flow 25 l/min

Hydraulic oil reservoir 30 l

Professional remote control with reach of 50 m.



With a wide range of attachments.



Basic bucket



Snow blower



Small dozer blade



PTO

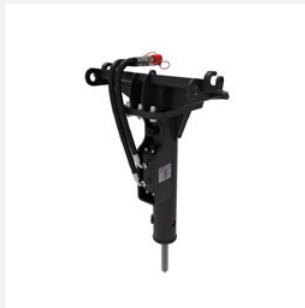

Mini hammer

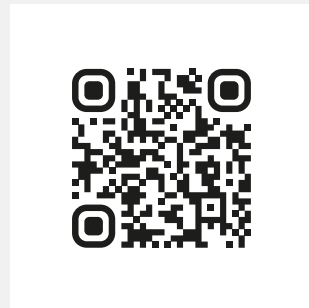

... plus 9 other attachments
on [first.green](https://www.first.green)



For more FIRSTGREEN products, visit
first.green

+420 737 633 733, info@first.green