

## ■ SCOPE OF WORK

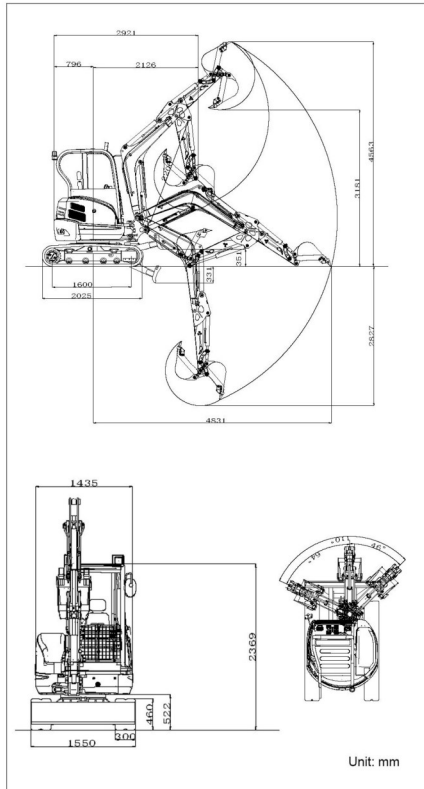

## ■ SPECIFICATION

	Model	R32PRO
<b>Basic parameters</b>	Machine working weight	lb(kg) 7055 (3200)
	Bucket capacity	ft(m <sup>3</sup> ) 2.83 (0.08)
	Travel speed low/high speed	mph(Km/h) 0-1.1/0-1.7 (0-1.8/0-2.8)
	Gradeability	(%) 30%
	Ground pressure	psi(Kpa) 8093 (36)
	Maximum digging force	(kN) 6070 (27)
	Maximum digging radius	in(mm) 190.2 (4831)
	Maximum digging depth	in(mm) 111.3 (2827)
	Maximum digging height	in(mm) 179.6 (4563)
	Maximum unloading height	in(mm) 125.2 (3181)
	Maximum deflection angle	(°) 110
	Track extension range	in(mm) -
<b>Engine</b>	Engine brand	Kubota
	Engine model	V1505
	Maximum horsepower	(hp) 25
	Maximum power	(Kw) 18.5
	Maximum speed	(rpm) 2300
	Displacement	gal(L) 0.4 (1.5)
	Number of cylinders	4
	Cooling method	Water-cooled
	Engine oil change amount	gal(L) 1.4 (6)
	Fuel form	Diesel
<b>Body</b>	Fuel grade	0/-10
	Theoretical fuel consumption	(L/h) 1.3-1.5
	Transport length	in(mm) 115 (2921)
	Transport width	in(mm) 61 (1550)
	Transport height	in(mm) 97.8 (2485)
	Counterweight ground clearance	in(mm) 20.6 (522)
	Bucket width	in(mm) 15.7 (400)
	Boom length	in(mm) 87.4 (2220)
	Arm length	in(mm) 63.8 (1620)
	Bulldozer blade width	in(mm) 61 (1550)

## ■ HYDRAULIC SYSTEM

Main pump type/model	Load sensitive piston pump/45	Maximum set pressure (Mpa)	20MPa
Main pump brand	Taifeng	Travel hydraulic motor type	LTM03AX
Main pump maximum flow rate	99 L/min	Travel motor brand	Likechuan
Multi-way valve	Load sensitive 9-way hydraulic multi-way valve	Motor displacement	15.4/23.2
Multi-way valve brand	Taifeng	Slewing hydraulic motor type	Likechuan
Rated set pressure	18MPa	Displacement	18.1

- Please read the instruction manual carefully and use the machine correctly.
- Always wear a seat belt when working. (ROPS specifications only)
- If you are operating construction machinery with a machine mass of less than 3 tons, you must take the "Special Training for Vehicle-Mounted Construction Machinery Operation" course beforehand. If the machine mass is 3 tons or more, you must take the "Vehicle-Mounted Construction Machinery Operation Skills Course".
- To prevent breakdowns and accidents, be sure to inspect the machinery regularly.
- Specific voluntary inspections are required to be carried out by an inspection company registered with the Minister of Health, Labor and Welfare or the Director-General of the Labor Standards Inspection Bureau.

**VMAX  
USA**

Grant Nelson  
406-490-6419  
www.vmaxusallift.com  
sales@vmaxusallift.com

MINI EXCAVATOR

**R32 PRO**



# High performance, more choices.

Improved basic performance and provided many new options to better meet the needs of various fields.

MINI EXCAVATOR

# R32 PRO



**Powerful performance more efficient**

Meets Euro 5 emission standards  

Possessing excellent perfection and reliability, it has improved its basic performance and provided many new options to better meet the needs of various fields.



# PERFORMANCE

## Pursuing higher performance of machines

### More energy-saving and efficient

This system controls the hydraulic oil discharge flow rate by feeding back the "pump discharge pressure" and "actuator load pressure" to the LS regulator mounted on the hydraulic pump, and supplies only the required flow rate to the control valve.



- Smooth operation thanks to lever operation and discharge adjustment according to work load.

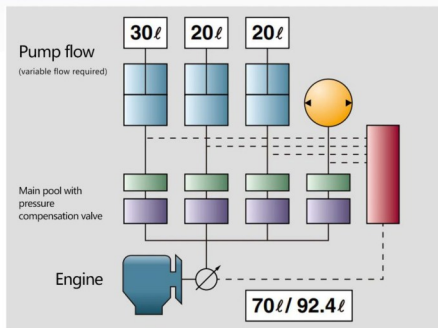

- Of the maximum discharge volume of 92.4L, it detects the required flow rate of 70L for the work equipment and discharges only 70L from the pump, so there is no waste.

**fuel cost**  
**About 5% up**

※Current machine ratio



**The hose is clean around**

Restrain the looseness of boom cylinder hose to prevent damage.



### Large LCD display

The LCD screen has a clear display and rich colors, ensuring a user-friendly interface. It can display the key operating parameters of the excavator, such as engine speed, hydraulic pressure, fuel level, temperature, etc., allowing the operator to grasp the equipment status at any time and improve work efficiency and safety.

### Assistive device settings (standard mode)

The arm's raking position can be set in any direction, depending on the attachment. It can be easily set using the hand-held toggle button, so you can respond quickly when switching between buckets and flatbeds on site.



# COMFORT/SAFETY

Safer, more comfortable and easier to operate

2-post ROPS/OPG · 4-post ROPS/OPG

Canopy, cab + seat belt

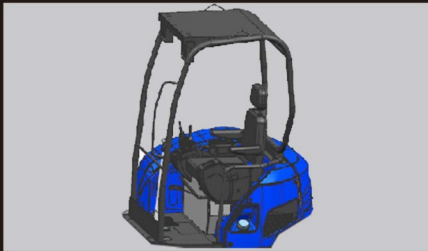

Walking speed gear

Equipped with fast and slow speed function, the driver can manually select the driving speed mode, which is suitable for a variety of operating conditions. It is more conducive to production operation and is convenient and fast.

Easy-to-operate dial type accelerator



Auto idle switch



## AUTO IDLE

When the control lever is returned to neutral, the engine will be in an idling state after 4 seconds, and when the control lever is moved again, the engine speed will immediately rise to the original speed. As a result, fuel can be saved by about 10%, and noise can be reduced, so work in urban areas and at night can be performed with peace of mind.

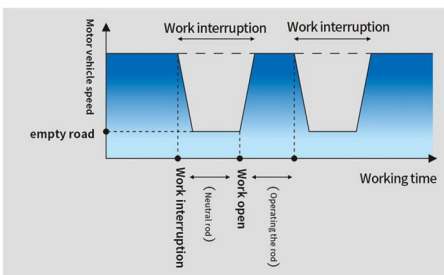

## Numerous safe specifications to prevent damage and trouble

Walking pedals

- **Waterproof connector with cover**

A waterproof connector harness with a cover that exhibits a high level of waterproof performance prevents troubles in the electrical system.

- **Front hose interior**

The internal type prevents damage to the hose during work.

- **Front hose cover**

Prevents the operator from being exposed to pressurized oil in the event of a hose burst.

- **Glass fiber filter**

A high-precision glass fiber filter is used for the hydraulic oil filter. It has excellent dust trapping performance and is safe with little deformation and damage.

- **X frame + Katayama type track frame adopted**

The crawler is good at removing mud, making it easy to remove soil and wash the car.

- **Divided dozer hose**

By splitting the hose in the middle, maintenance and replacement of the hose can be easily performed even in the event of unexpected damage.

- **Auto glow**

It automatically senses the water temperature and makes it possible to start the engine with the optimum and shortest glow time.

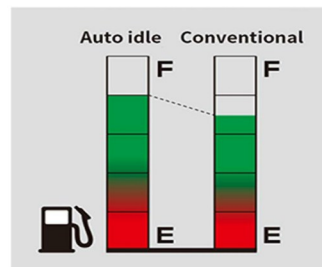

# MAINTENANCE

A reassuring, safe design that offers excellent maintainability and durability.



- 1 Air Filter
- 2 Oil filter
- 3 Exhaust filter
- 4 Multi-way valve

## Full open bonnet

The rear cover and side cover can be fully opened for easy maintenance.



## Comfortable work space

Spacious boarding and alighting space with large doors make it easy to get on and off. It became smoother and the visibility of the foot during operation expanded. A bright and comfortable space contributes to reducing operator stress.

## Air conditioner

The vehicle is equipped with air conditioning to provide a comfortable driving environment.



## Cab specifications

### LED light



# OPTION

Adapt to various working environments

## Soft canopy specification (R32 Pro)



Roof type

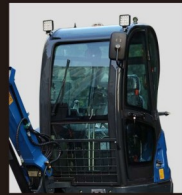

Cab type



Openable windshield



Comfortable cab

R32 Pro boom length: 2220 mm

R32 Pro Arm length: 1620 mm

\*Long arms are reinforced on both sides only.

## Rubber Engineering Tracks



It uses industrial rubber tracks, which are thick and durable and suitable for a variety of terrains.

Large Capacity Bucket

## Bulldozer Blade



## Super change (standard equipment)

### 4 pattern multi (optional)

Different operation modes can be changed to adapt to various operating habits.

## Assistive devices

- Hydraulic Breaker
- Rotary Drilling
- Hydraulic tilt bucket
- Mud bucket
- Grass rake
- Scarifier